

SINGLE-STAGE MOSFET AMPLIFIERS

I. OBJECTIVES

- Analyzing the CS and CG configurations.
- Determining the effect of the finite load resistance on the parameters of the amplifier.

II. COMPONENTS AND INSTRUMENTATION

Use the breadboard, an IRFZ24N MOSFET, some resistors and capacitors. The supply is obtained from the dc regulated voltage supply. The input voltage is obtained from the signal generator. To visualize the voltage waveforms, a dual-channel oscilloscope is used.

The terminals of the IRFZ24N MOSFET are shown in Fig. 1.

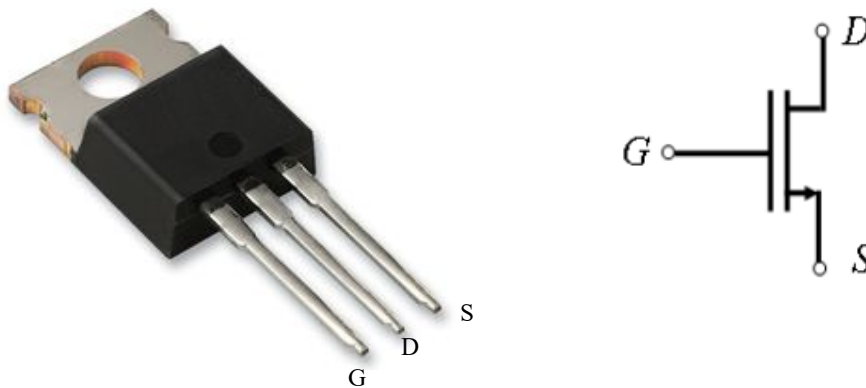

Fig. 1. IRFZ24N MOSFET – pinout diagram

III. PREPARATION

For the MOSFET, consider $I_D=1.25\text{mA}$; $\beta=5\text{mA/V}^2$, $V_A=100\text{V}$.

1.P. DC equivalent circuit

- Draw the dc equivalent circuit, based on the schematic in Fig. 2.
- Compute the quiescent point, $Q(V_{DS}, I_D)$.

2.P. Small-signal equivalent circuit

- Draw the small signal equivalent schematic in midfrequency for this stage.
- Compute values of the small signal model parameters of T: g_m ; r_{ds} .
- What is the configuration of this stage? Justify your answer.
- Find the expressions and values of the voltage gain $A_v = v_o/v_i$, the input resistance R_i and the output resistance R_o .
- Plot $v_G(t)$, $v_o(t)$ and $v_s(t)$ for $v_i(t) = 100\sin\omega t[\text{mV}]$.

- Recompute any of the previously computed values that are subject to change when the load resistance becomes $R_L = 2.2\text{ k}\Omega$.

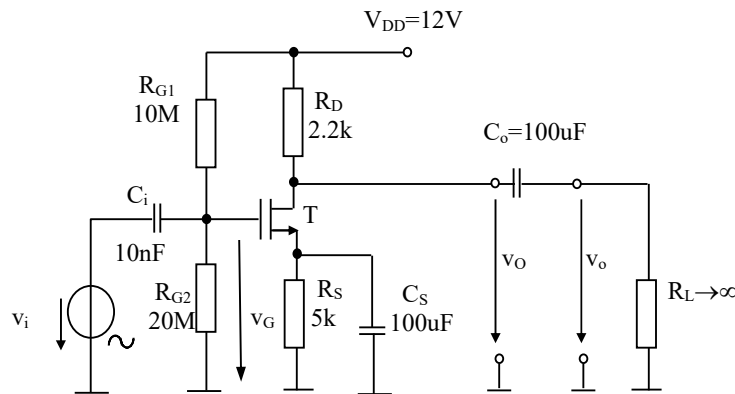

Fig. 2. CS MOSFET amplifier schematic

IV. EXPLORATION AND RESULTS

1. CS amplifier

Exploration

- Build the circuit in Fig. 2.
- The input voltage is $v_i(t) = 100\sin\omega t$ [mV], frequency of 5kHz.
- Visualize the input and output voltages on the oscilloscope, simultaneously, with both channels in AC mode.
- Is the amplifier inverting or non-inverting?
- Determine the gain $A_v = v_o/v_i$, by measuring the amplitudes of the input and output voltages.
- Set the output channel to DC mode. What is the value of the DC component of the output voltage?
- Increase the amplitude of the input voltage, until the output voltage reaches saturation.
- Starting from 5kHz, increase the frequency of the input voltage, until the output voltage starts to decrease.
- Come back to $v_i(t) = 100\sin\omega t$ [mV]. Add $R_L = 2.2\text{ k}\Omega$ at the output of the circuit. Determine the new value of the gain.

Results

- The waveforms of the input and output voltages, simultaneously, with both channels in AC mode.
- The amplitudes of the input and output voltages, and the gain.
- The waveforms of the input and output voltages, simultaneously, with the output channel in DC mode.
- The value of the DC component of the output voltage.
- The maximum value of the input voltage that can be amplified without reaching saturation.
- The maximum frequency of the input voltage, for which the output has the same amplitude as for 5kHz.
- The new value of the gain, after adding the finite load resistance in the circuit.

2. CG amplifier

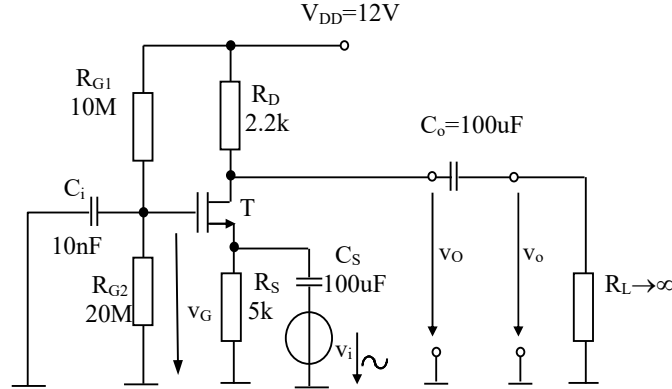

Fig. 3. CG MOSFET amplifier schematic

Exploration

- Build the circuit in Fig. 3.
- The input voltage is $v_i(t) = 100\sin\omega t$ [mV], frequency of 5kHz.
- Visualize the input and output voltages on the oscilloscope, simultaneously, with both channels in AC mode.
- Is the amplifier inverting or non-inverting?
- Determine the gain $A_v = v_o/v_i$, by measuring the amplitudes of the input and output voltages.
- Set the output channel to DC mode. What is the value of the DC component of the output voltage?
- Add $R_L = 2.2 \text{ k}\Omega$ at the output of the circuit. Determine the new value of the gain.

Results

- The waveforms of the input and output voltages, simultaneously, with both channels in AC mode.
- The amplitudes of the input and output voltages, and the gain.
- The waveforms of the input and output voltages, simultaneously, with the output channel in DC mode.
- The value of the DC component of the output voltage.
- The new value of the gain, after adding the finite load resistance in the circuit.

Table 1 – Results for the CS and CG amplifier

Parameter	Common source CS		Common gate CG	
	Computed	Measured	Computed	Measured
Gain $A_v = v_o/v_i$ (R_L - infinite)				
Gain $A_v = v_o/v_i$ ($R_L = 2.2 \text{ k}\Omega$)				

REFERENCES

1. Oltean, G., Electronic Devices, Editura U.T. Pres, Cluj-Napoca, ISBN 973-662-220-7, 2006
2. Sedra, A. S., Smith, K. C., Microelectronic Circuits, Fifth Edition, Oxford University Press, ISBN: 0-19-514252-7, 2004
3. <http://www.bel.utcluj.ro/dce/didactic/fec>